

THIS DRAWING IS UNPUBLISHED. RELEASED FOR PUBLICATION
 © COPYRIGHT BY TYCO ELECTRONICS CORPORATION. ALL RIGHTS RESERVED.

LOC	DIST	REVISIONS					
AF	50	P	LTR	DESCRIPTION	DATE	DWN	APVD
			H2	ECR-07-018635(REDRAWN IN AUTOCAD)	08AUG07	HMR	GP

- CONTINUOUS STRIP ON REELS
- WIRE RANGE FOR NEW APPLICATIONS: 3200-3900 CMA
 (WIRE RANGE APPROVED FOR APPLICATIONS IMPLEMENTED
 PRIOR TO 2005: 1600-4200 CMA).

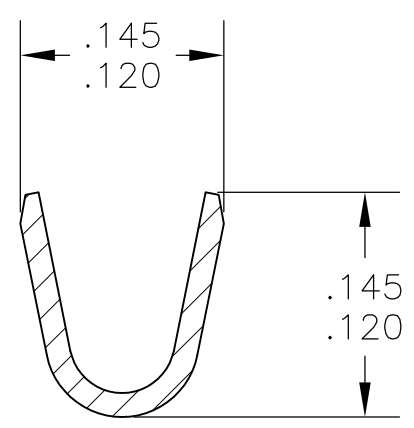
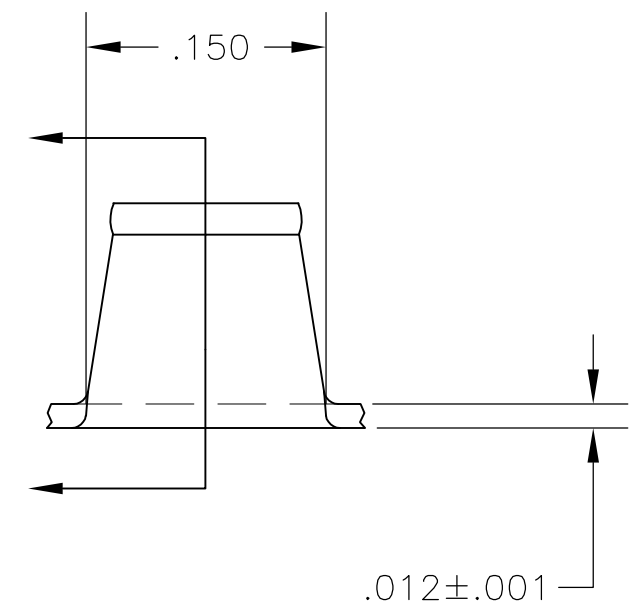
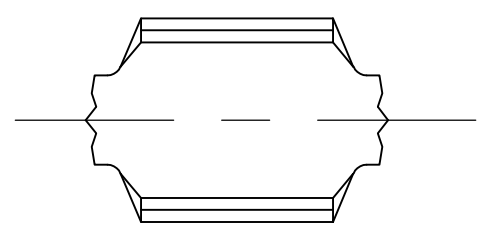

42329-1
 PART NO

THIS DRAWING IS A CONTROLLED DOCUMENT.		DWN	M.S. FEHER	14NOV2005	Tyco Electronics Corporation Harrisburg, PA 17105-3608															
DIMENSIONS: INCHES		CHK	G.D. PORTA	14NOV2005	NAME															
TOLERANCES UNLESS OTHERWISE SPECIFIED:		APVD	G.D. PORTA	14NOV2005	SPLICE															
<table border="0"> <tr><td>0 PLC</td><td>± -</td></tr> <tr><td>1 PLC</td><td>± -</td></tr> <tr><td>2 PLC</td><td>± -</td></tr> <tr><td>3 PLC</td><td>± .015</td></tr> <tr><td>4 PLC</td><td>± -</td></tr> <tr><td>ANGLES</td><td>± 1°</td></tr> </table>		0 PLC	± -	1 PLC	± -	2 PLC	± -	3 PLC	± .015	4 PLC	± -	ANGLES	± 1°	PRODUCT SPEC		SIZE		CAGE CODE	DRAWING NO	RESTRICTED TO
0 PLC	± -																			
1 PLC	± -																			
2 PLC	± -																			
3 PLC	± .015																			
4 PLC	± -																			
ANGLES	± 1°																			
MATERIAL STEEL		FINISH .000100 MIN NICKEL		WEIGHT		A3 00779 C-42329		—												
CUSTOMER DRAWING				SCALE	5:1	SHEET	1 OF 1	REV H2												